

Pb Free Plating Product

U20C20D/U20C40D/U20C60D



20 Ampere Heatsink Doubler Polarity Fast Recovery Half Bridge Rectifiers

Features

- ★ Latest GPP technology with super fast recovery time
- ★ Low forward voltage drop
- ★ High current capability
- ★ Low reverse leakage current
- ★ High surge current capability

Application

- ★ Automotive Inverters and Solar Inverters
- ★ Plating Power Supply, SMPS, Motor Control and UPS
- ★ Car Audio Amplifiers and Sound Device Systems

Mechanical Data

- ★ Case: Heatsink TO-220AB/TO-220CE
- ★ Epoxy: UL 94V-0 rate flame retardant
- ★ Terminals: Solderable per MIL-STD-202 method 208
- ★ Polarity: As marked on diode body
- ★ Mounting position: Any
- ★ Weight: 2.2 gram approximately

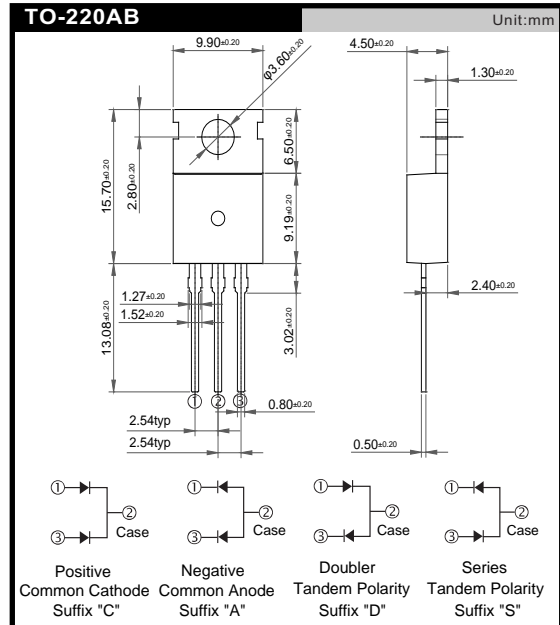

MAXIMUM RATINGS AND ELECTRICAL CHARACTERISTICS

Rating at 25°C ambient temperature unless otherwise specified.
 Single phase, half wave, 60Hz, resistive or inductive load.
 For capacitive load, derate current by 20%.

	SYMBOL	U20C20D	U20C40D	U20C60D	UNIT
Maximum Recurrent Peak Reverse Voltage	VRRM	200	400	600	V
Maximum RMS Voltage	VRMS	140	280	420	V
Maximum DC Blocking Voltage	VDC	200	400	600	V
Maximum Average Forward Rectified Current Tc=125°C	IF(AV)	20.0			A
Peak Forward Surge Current, 8.3ms single Half sine-wave superimposed on rated load (JEDEC method)	IFSM	200	175		A
Maximum Instantaneous Forward Voltage @ 10.0 A	VF	0.98	1.3	1.7	V
Maximum DC Reverse Current @Tj=25°C At Rated DC Blocking Voltage @Tj=125°C	IR		5.0 100		uA uA
Maximum Reverse Recovery Time (Note 1)	Trr		35		nS
Typical junction Capacitance (Note 2)	CJ	120	70		pF
Operating Junction and Storage Temperature Range	TJ, TSTG	-55 to +150			°C

NOTES : (1) Reverse recovery test conditions IF = 0.5A, IR = 1.0A, Irr = 0.25A.
 (2) Measured at 1.0 MHz and applied reverse voltage of 4.0 Volts DC.

FIG.1 - FORWARD CURRENT DERATING CURVE

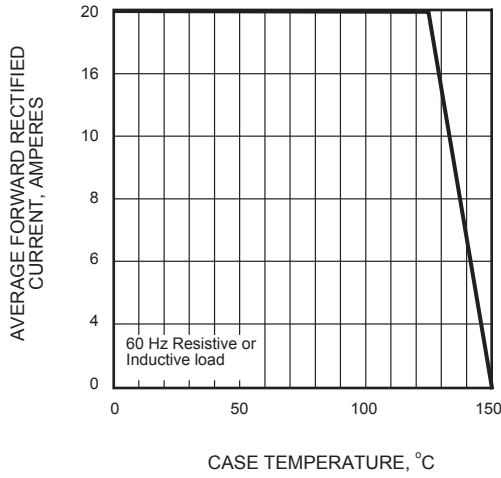

FIG.2 - MAXIMUM NON-REPETITIVE PEAK FORWARD SURGE CURRENT

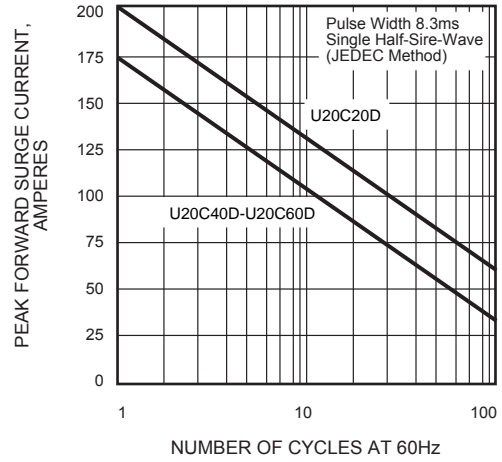

FIG.3 - TYPICAL INSTANTANEOUS FORWARD CHARACTERISTICS

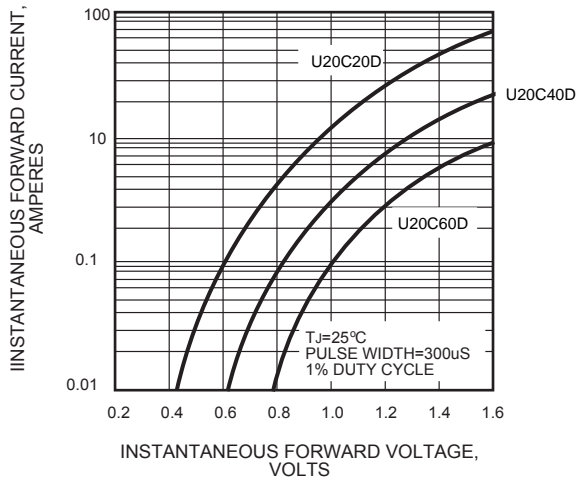

FIG.4 - TYPICAL REVERSE CHARACTERISTICS

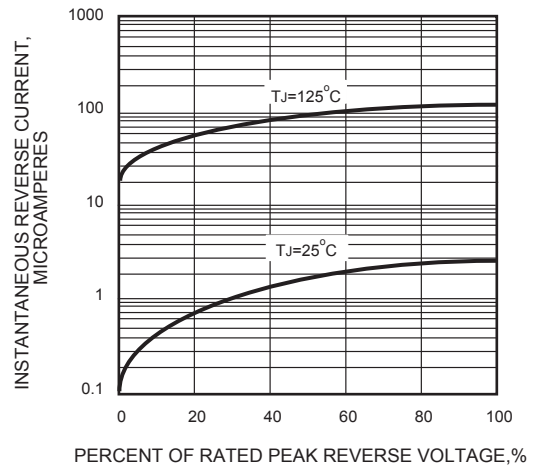

FIG.5 - TYPICAL JUNCTION CAPACITANCE

